

HIGH SPEED 8/6 CLOSED LOOP CONTROL OF SWITCH RELUCTANCE MOTOR POWERED BY SOLAR PHOTOVOLTAICS

Neeraj Solanki¹ & Virendra Kumar Sharma²

¹*Research Scholar, Department of Electrical Engineering, Bhagwant, University, Ajmer, Rajasthan, India*

²*Professor, Department of Electrical Engineering, Bhagwant University, Ajmer, Rajasthan, India*

Received: 25 Mar 2019

Accepted: 15 Apr 2019

Published: 30 Apr 2019

ABSTRACT

The High Speed 8/6 Switched Reluctance Motor (SRM) is a member of machine family. The motor's simple construction, ruggedness and inexpensive manufacturability makes more attractive for industrial applications. The advantages of High Speed 8/6 Switched Reluctance Motor (SRM) are highly reliable, good performance and reduce the maintenance. The absence of windings in rotor and permanent magnets stretches probability to attain very high speeds and turned High Speed 8/6 Switched Reluctance Motor (SRM) into perfect solution for operation in hard conditions like presence of vibration or impact. In this paper a detailed analysis and modelling of three different types of converters used in with the four phase High Speed 8/6 Switched Reluctance Motor (SRM). These converts are R-Dump, Asymmetric and Bifilar type. Finally High Speed 8/6 Closed Loop Control of Switch Reluctance Motor Powered by Solar Photovoltaic's proposed in this paper. PI controller is used in closed loop and the simulation results are presented by using Matlab / Simulink platform.

KEYWORDS: *High Speed 8/6 Switched Reluctance Motor (SRM), Converters, R-Dump, Asymmetric, Bifilar, PI Controller*

INTRODUCTION

The Inherent simplicity, ruggedness and low cost of a High Speed 8/6 Switched Reluctance Motor (SRM) make it a viable for various general – purpose adjustable – speed applications. From past two decades the development of SRM drive is remarkably increased. The advantages over induction motor and permanent magnet synchronous motor shows more attention over SRM. Lesser price, enhanced performance, equal or better reliability, comparable or better efficiency, lower volume and ease of production and storage in comparison to AC and DC motor drives are some advantages [1-3]. Torque Ripple is the major problem in the SRM drive due to the lack of continuity in the generated torque. Through phase current overlapping this can be diminished to a great extent. Therefore, the converters used for SRM drive needs separate control for each phase so that the torque ripples can be reduced by phase current overlapping. Also because of back EMF, the stator current falls behind the reference current during the commutation of each SRM phase current. This means that during commutation, the phase current reaches zero after the reference current which causes negative torque and more ripples in the torque produced by the motor. Thus, the converter used in the SRM drive must have the quick commutation ability of phase currents, which will reduce torque ripples considerably. This is more important at higher speeds where commutation interval is very short [4].

From recent years, the development of alternative power sources such as photovoltaic (PV) modules, fuel cells and wind turbines has enthused due to the increased demand for energy. The PV modules are predominantly attractive as renewable sources due to their relative small size, noiseless operation, simple installation, and to the possibility of installing them closer to the user. In PV modules, the output voltage has a low dc amplitude value. In order to be connect, the SRM drive need extra power electronics technology. The PV modules output voltage should be boosted and converted into an ac voltage with high step up dc/dc converter with asymmetrical topology.

However, the conversion stages decrease the efficiency and make the system more complex [4]. The transformer less centralized configuration with one- stage technology uses only one inverter and a large number of series connected PV modules, called strings, are used in order to generate sufficient voltage to support the load [5]. The life cycle of the solar cell is more than 20 years, and it can minimize maintenance and management expenses. The output power of the solar cell is easily changed by the surrounding conditions such as irradiation and temperature, and also its efficiency is low.

Thus high efficiency is required for the power conditioning system (PCS), which transmits power from the PV array to the load. In general, a single-phase PV PCS consists of two conversion stages (i.e., dc/dc conversion stage and dc/ac conversion stage). In this paper presents the electronic approach is based on optimizing the control parameters, which include the supply voltage, turn-on and turn-off angles, and current level. The minimization of torque ripple through electronic control may lead to a reduction in the average torque, since the motor capabilities are not being fully utilized at all power levels.

SRM CHARACTERISTICS

In a switched reluctance machine, the stator has windings and the rotor is made of steel laminations without permanent magnets or conductors. The basic structure of three phase 6/4 SR motor is shown in Fig.1, the SR motor has salient poles on both stator and rotor, making it salient machine. The machine has 4 rotor poles and 6 stator poles, each stator poles has a concentrated coil wound on it. Two coils on the opposite stator poles are connected in serial or parallel, making one stator phase. The SR machine, when compared with the AC and DC machines, shows two main advantages:

It is very reliable machine since phase is largely independent magnetically, physically and electrically from the other machine phases.

Due to the lack of the conductors or magnets on the rotor, a very high speed (20000 - 50000 r.p.m) can be attained.

The Switched Reluctance Machine has some limitations:

It cannot be run directly from a DC bus or AC line, thus it must be commutated electronically.

Its salient structure causes strong non – linear magnetic characteristics, complicating its analysis and control.

The SRM shows strong torque ripple and noisy effect.

Figure 2 explains a SRM with rotor tooth pair aligned with the stator phase A-AI. The rotor is aligned and unaligned with the stator phase A-AI as shown in Figure 2 and Figure 1 respectively. The phase current cannot produce any torque at the aligned position as it is equilibrium point, but a small deviation of the rotor away from this point will produce a torque which will push the rotor back. In contrast, the unaligned position is an unstable equilibrium point because any small displacement of the rotor away from that point results in the rotor moving away.

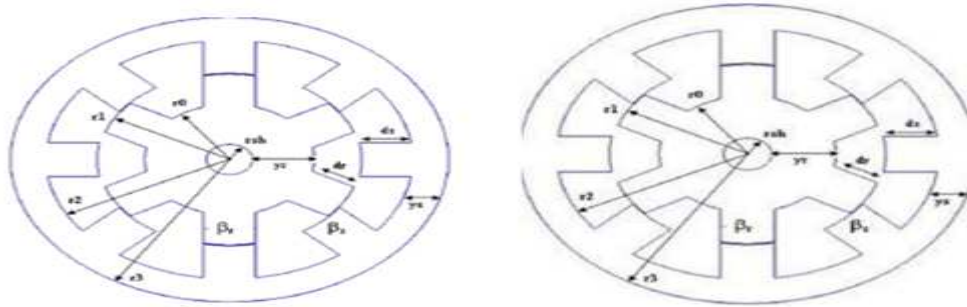

Figure 1: Cross Section of a 6/4 SRM (Phase A Is At Unaligned Position)

Figure 2: Cross Section of a 6/4 SRM (Phase A Is At Aligned Position)

NECESSITIES OF SRM CONVERTER

Selection of Converter topology is the major problem for certain application. Some of the essential requirements [6] of the SRM Converter are:

In each phase of motor, there should be one switch (minimum) is capable to conduct freely. Before the converter enters into the generation or demagnetisation region, it should accomplish to excite the phase. To increase the converter performance, the converter should satisfy some requirements like fast demagnetising time, faster excitation time, high efficiency and fault acceptance [4], [7]-[9].

The converter should allow phase overlap control, since the converter energy can be provided to one phase whereas at the same time it is removed from the other phase.

For controlling the phase currents at low speeds, Pulse Width Modulation (PWM) technique is used to control the phase voltage in the converter.

At every operation point, the sufficient current should be injected in the winding at high speeds, necessary high driving voltage is important. This control system may be hysteresis current control or single pulse. The demagnetising time can be reduced for avoiding negative torque by using this device.

The dc source should be delivered the demagnetisation energy from the leaving phase or should use it in the incoming phase.

The hysteresis losses and switching losses can be condensed by the converter, because in order to reduce the switching frequency it is capable of freewheeling during the chopping period.

The converter takes to be single rail of power sources because the voltage stress through semiconductors should decrease.

For reduction of the switching loss, the converter should need resonant circuit to apply Zero-Voltage or Zero-Current switching.

Number of semiconductor switches should be less.

To improve the power factor, the power factor circuit correction circuit should be applied. Converter should require little complexity. Efficiency and application of this converter is defined by selecting the appropriate switching strategy, dwell angle and control technique.

CONVERTER CATEGORIES IN SRM

The converter fed SRM is power-driven from fixed dc-link voltage, which is established by an ac/dc converter or directly by a Battery. The group of suitable converter and control scheme depends on the performance and the necessities of application of SRM [4], [10]. The features of SRM operation must be shown before the converter types are to be used. Based on operation these features can be summarized by 3 tasks [6]:

In the Inductance profile, the current should be supplied into the phase only in the positive gradient period.

During the phase energizing of the motor phase, the torque must be maximized. By shaping the phase current by maximizing the amount of it at rise time period and then minimizing at fall time period by this it can be achieved.

During the commutation the stored magnetic energy must be returned to the DC supply.

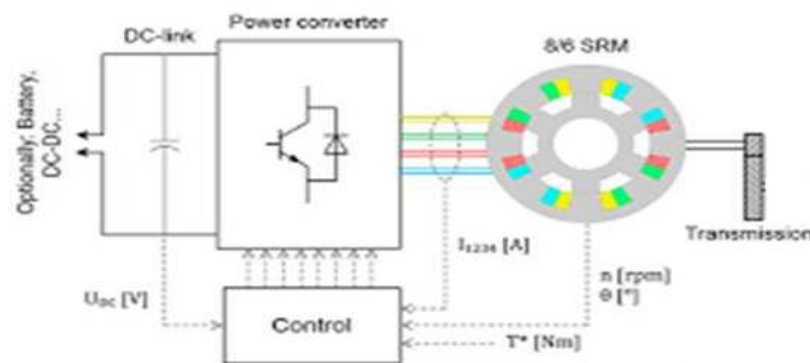

Figure 3

R-DUMP CONVERTER

R-dump is one of the converters with one switch (IGBT) and one diode for every phase. The resistance R determines the switch voltage and also the power dissipation.

To attain both realistic stress on the switch (higher resistance R increased), and suitable fall time of the current (lower resistance R increased) by changing the value of resistance R. While the T1 switch is turned off, the current through diode D1, charging capacitor CS, and afterward flows through the external resistor R.

This resistor moderately dissipates the energy stored in the magnetized phase [11], [12]. R-dump converter type is shown in Figure 4.

ASYMMETRIC CONVERTER

Asymmetric bridge converter is used for high switching voltage to have fast developed of the excitation current. Asymmetric bridge converter is shown in Fig.5. In each phase the converter consists of two power electronic switches and two diodes, so that the unipolar switching strategy is achieved. In every phase, the lower switch is used in charge of commutation, while the PWM switching control can be performed by the upper one.

Every phase can be controlled separately. Magnetization, demagnetization and freewheeling mode [4] are defined as the three current modes of operation. In the inner current control loop of the SRM drive, less current ripple and a improved frequency reaction can be obtained by using unipolar switching approach.

SRM is generally controlled by either voltage or current control in the asymmetric converter. Phase current can be controlled accurately that means torque is accurately controlled and the decrease of torque ripple or noise is achieved.

This is the main benefit of current control over voltage control the main demerit is it requires a larger heat sink for cooling because the one switch that is always in the current conduction path increases the losses in the converter so it reduces the efficiency of the system. From this paper, it is found that the asymmetric converter type is suitable for very high speed operation of SRM drive because of the quick rise and fall times of current and moreover it give negligible shoot through faults.

Because of the nonappearance of the resistance commutation circuit or any coil that is added to the converter, copper losses is not presented in the asymmetric converter. So, for high power SRM drives, Asymmetric converter is considered as the most suitable converter.

BIFILAR CONVERTER

The two coils are main switch and the flywheel diode in per phase circuit as shown in Fig.6. The main switch is connected to main coil and the flywheel diode is connected to auxiliary coil.

The main coil and auxiliary coil are wound into diametrically opposite stator poles parallel and the end of the bifilar coil is connected with reverse polarity.

The turns ratio is one for both the coils. The power supplies electrical energy to the main coil when the main switches are turned on. Similarly the flywheel diodes connected to the auxiliary coil are turned on by the EMF of the auxiliary coil when the main switches are turned off.

Through the magnetic coupling of the main coil and the auxiliary coil with the continuing current, the stored magnetic energy in the motor is released.

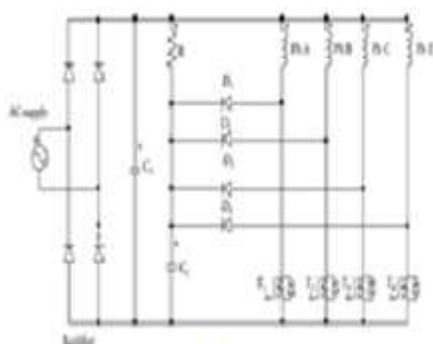

Figure 4: R-dump Converter

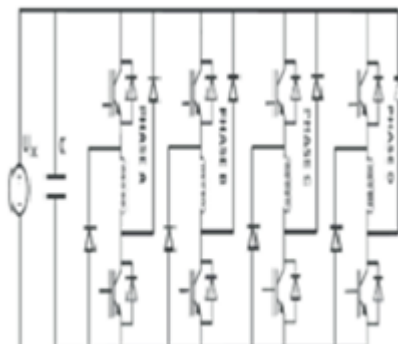

Figure 5: Asymmetric Converter

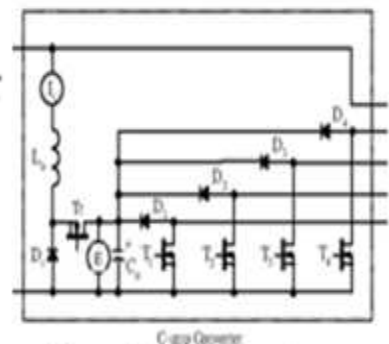

Figure 6: Bifilar converter

Figure 4: Dump Converter, Figure 5: Asymmetric Converter, Figure 6: Bifilar Converter.

Comparison of the Three Phase Power Converter Main Circuit for Three Topologies

Table 1: Comparison of Three Topologies

Dynamics	R-Dump	Asymmetric	Bifilar
Average supply voltage of phase winding	V_s	V_s	V_s
Average commutated voltage of phase winding	Based on communication resistance	V_s	V_s
Rated voltage of the flywheel diodes	V_s	V_s	$> 2 V_s$
No. of switches	V_s	V_s	$> 2 V_s$
Independence of the circuit	Independent	Independent	Independent
Others	Loss in communication resistance	No of switches are more	High copper loss

Proposed Model

In this paper a PV model is used for a dc supply to the converter and a dc/dc boost converter is also used to boost the output of the PV module. To form a closed loop a PI controller is used in the model, where in PID controller the derivative of the error is not used. In various industrial control systems this control feedback mechanism is used. The PI controller attempts to decrease the error which is the difference between the measured values to the desired value. The PI combination is used to eliminate the steady state error and to increase the speed of the response. The current value of the error is equal to the output response of the proportional term, whereas the integral term is proportional to both magnitude and duration of the error.

SIMULATION & RESULTS

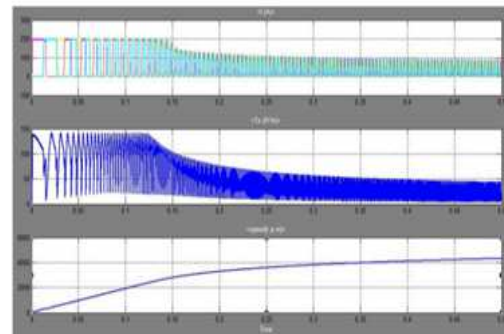
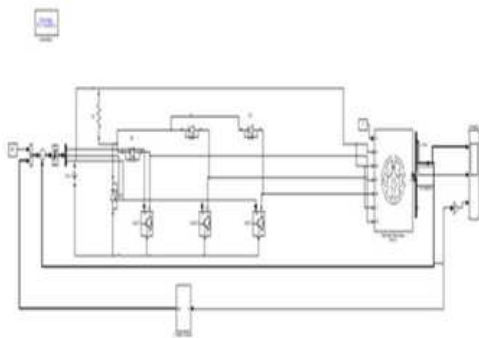

Figure 8: Shows R-Dump Matlab/Simulink Model.

Figure 9: Shows Performance of the SRM Drive of R-Dump Converter.

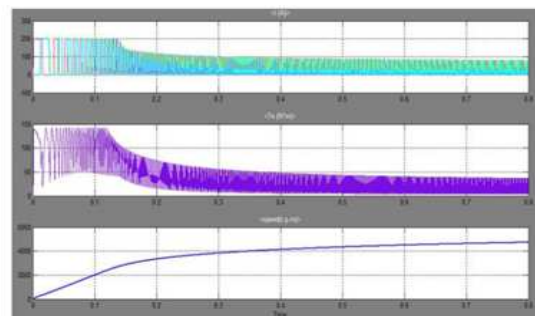
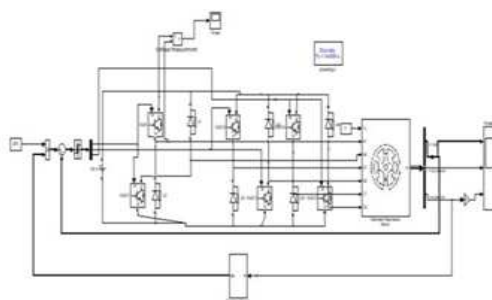

Figure 10: Shows Asymmetric Converter Matlab / Simulink Model.

Figure 11: Shows The Performance of the SRM Drive of Asymmetric Converter.

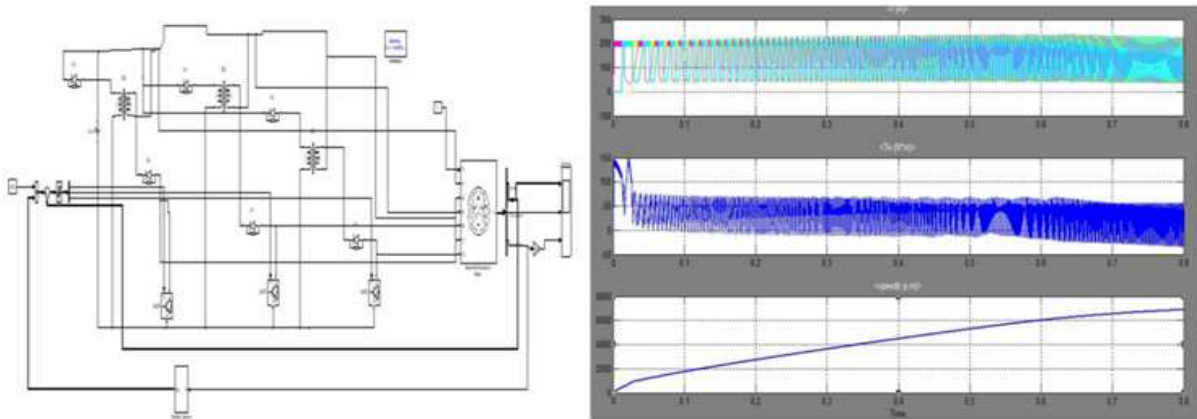

Figure 12: Shows Bifilar Converter Matlab / Simulink Model.

Figure 13: Shows The Performance of the SRM Drive of Bifilar Converter.

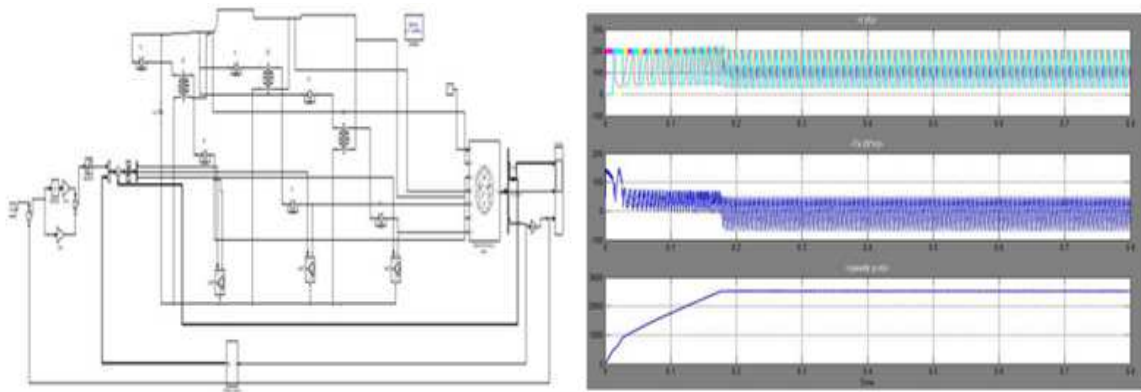

Figure 14: Shows Closed Loop Bifilar Converter With PI Controller Matlab / Simulink Model

Figure 15: Shows The Performance Of SRM Drive Of Bifilar Converter With Pi Controller.

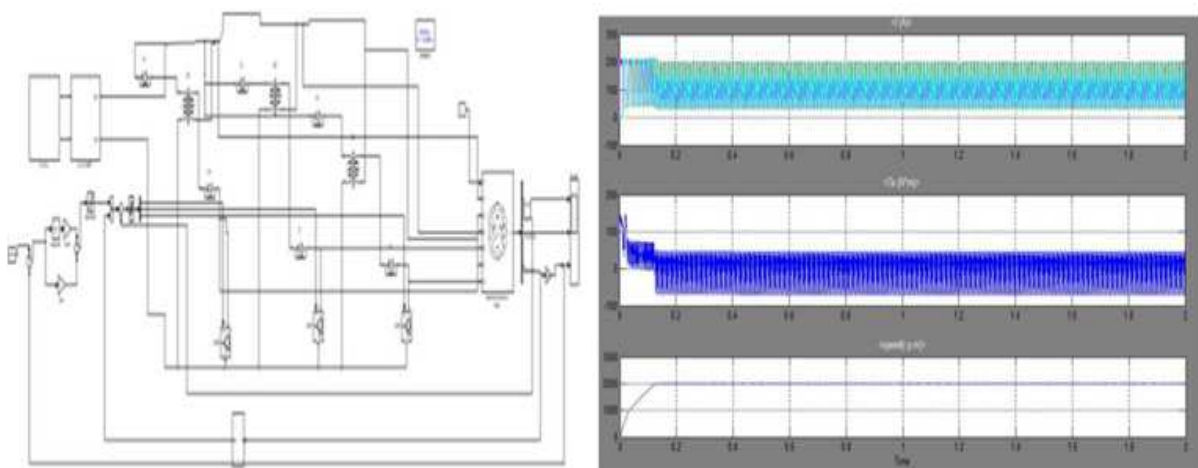

Figure 16: Shows PV Based Bifilar Converter Matlab / Simulink Model.

Figure 17: Shows The Performance Of The SRM Drive Of PV Based Bifilar Converter.

CONCLUSIONS

Power systems control, adjustable speed drives, uninterruptible power supplies, power quality and interfacing drive control are such fields in which power electronics applications requiring high voltage converters have been gradually increasing. Most application demands high voltage gain converters applications to SRM drive. To develop the performance, adapt to necessities and avoid proprietary technologies, several converter topologies have been proposed in the literature. This paper deals with the PV based SRM drive with closed loop control. Therefore, improvements to the efficiency of the proposed converter have been accomplished. The residual energy is effectively removed during the non-operating condition, without extreme duty ratios and turns ratios; the proposed converter achieves high step-up voltage gain and supports the load condition, of up to 13 times the level of input voltage.

REFERENCES

1. Samia M. Mahmud, Mohsen Z. El-Sherif, "Studying Different Types of Power Converters Fed Switched Reluctance Motor," *International Journal of Electronics and Electrical Engineering*, vol. 1, no. 4, pp. 281-290 December 2013.
2. T. Wichert, "Design and construction modifications of switched reluctance machines," Ph.D. Thesis, Warsaw University of Technology, 2008.
3. Y Hasegawa, K. Nakamura and O. Ichinokura, "Development of a switched reluctance motor made of pretender," in *Proc. 2nd Int. Symp. On Advanced Magnetic Materials and Applications, Journal of Physics*, 2011.
4. M. T. Lamchich, *Torque Control*, InTech Publisher, February 10, 2011, ch. 8.
5. R. D. Doncker, D. W. J. Pülle, and A. Veltman, *Advanced Electrical Drives: Analysis, Modeling, Control*, Springer Press, 2011, ch. 10.
6. E. S. Elwakil and M. K. Darwish, "Critical review of converter topologies for switched reluctance motor drives," *International Review of Electrical Engineering*, vol. 2, no. 1, January-February 2011.
7. W. Ahn, Liang and D. H. Lee, "Classification and analysis of switched reluctance converters," *Journal of Electrical Engineering & Technology*, vol. 5, no. 4, pp. 571-579, 2010.
8. Z. Grbo, S. Vukosavic and E. Levi, "A novel power inverter for switched reluctance motor drives," *FACTA Universitatis (NIS), Elec. Eng.*, vol. 18, no. 3, pp. 453-465, December 2005.
9. B. Singh, R. Saxena, Y. Pahariya, and A. R. Chouhan, "Converters performance evaluation of switched reluctance motor in simulink," *International Journal of industrial Electronics and Control*, vol. 3, no. 2, pp. 89-101, 2011.
10. P. Vijayraghavan, "Design of switched reluctance motors and development of a universal controller for switched reluctance and permanent magnet brushless DC motor drives," Ph.D. dissertation, Faculty of the Virginia Polytechnic Institute and State University, Blacksburg, Virginia, November 2001.